



## How Are Those New Year's Resolutions Working Out For You?

Every year millions of people make New Year's resolutions to lose weight, stop smoking, be a better person... and every year several weeks later the resolutions fall by the wayside. Why is that? The problem is we are trying to change habits that have been a part of our every day lives for so many years that they have become ingrained in our system. In order to change those habits you actually have to substitute a new behavior for the old and make a conscious decision to stick to it until it becomes the new habit.

It is the same trying to create a culture change in the operation and maintenance of equipment, only on a much larger scale. Now you are not trying to change the habits of one person, but of a whole organization that has a corporate culture developed and reinforced to act certain ways. The reason that most transformation processes fail, is because leaders, managers and employees often aren't aware of their unconscious habits, and how these are perpetuating the old culture.

Economics and rationality don't seem to be the motivators that you would expect them to be for individuals who make resolutions to break bad habits. People in the U.S. alone spend over \$35 billion dollars on weight loss products yearly. Each smoker spends enough money each year on cigarettes that if they took that money, from the time they were 17 years old (the average starting age for a smoker) and put it in a

## Creating a Reliability Network: Overcoming Organizational Inertia

By Winston P. Ledet

Numerous company sites have attempted to improve their reliability through the years but keep backsliding after some success. The primary cause of this experience is underestimating the resistance in the organization and the momentum needed to overcome that resistance. The culture of a site is embedded in the work habits of the workers, and these habits are the resistance to change. If the reliability improvements are approached from a strictly functional point of view, the program produces improvements in individual pieces of equipment through technical approaches using the reliability tools. Most sites focus on "bad actors" in order to get the most improvement for their efforts. This produces improvements in performance of specific pieces of equipment and is quite satisfying from an individual point of view. However, these technical improvements in the equipment do not address the biggest root cause of unreliability, which is the work habits of the people who operate, maintain, and upgrade the equipment. To overcome bad habits, the organization has to engage all of the workers in creating reliability through good work habits. To create these new habits a supporting structure in the organization is required.



In the DuPont benchmarking studies in the 1980's it was recognized that the main structure change needed in the organization was to eliminate the "functional silos" where each function works mostly with other people in the same function. Operators worked with other operators, mechanics worked with other mechanics, procurement people worked with procurement people and engineers worked with other engineers. Also the organizations were seen as hierarchical structures and information had to be passed up the line before going to other functions. The organizations that won the Total Productive Maintenance award in Japan had achieved the award by using cross-functional teams to make improvements in the equipment. This process created a number of connections between the mechanics, operators, procurement people and the engineers so that

Creating...continued on page 2

How Are...continued on page 3

### What's Inside?

Creating a Reliability Network...  
Calendar

1-3  
4

How Are Those New Year...  
What's Happening!

1, 3  
4

**Creating...cont. from page 1**

many routes were now available to get work done. The workers were no longer constrained by going through the hierarchy to get other functions to participate in the improvements. This allowed the workers to structure themselves to serve the needs of particular

network is the result of past associations where people worked with others from different functions on a particular job that created a bond based on the meaningfulness of the work that they did together. These are the people who trust each other to do things in a certain way and that creates the meaningfulness.

successful, the word travels in the shadow network, which reduces the resistance to the particular change. Of course, if the shadow network is rather sparse, it will take a long time for the new change to be accepted. That is why it is smart to build up a large shadow network if you want to change the whole culture of

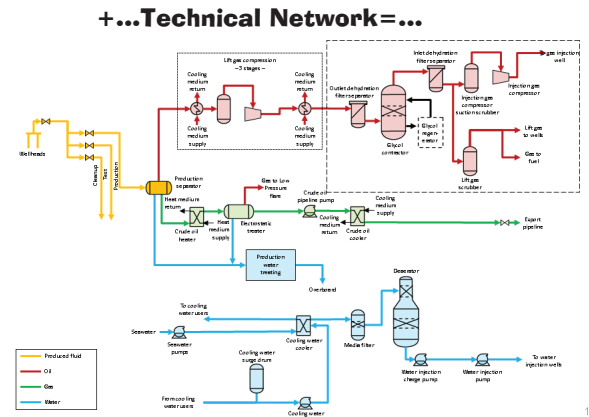
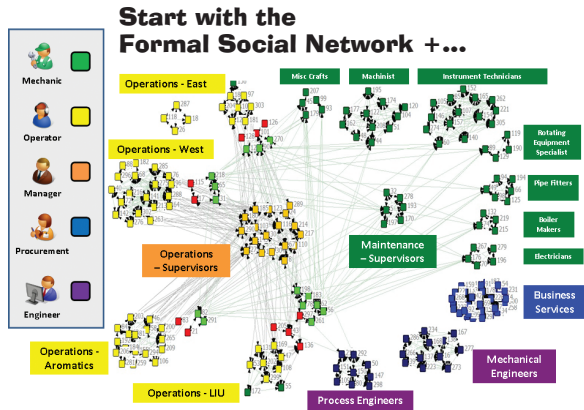

pieces of equipment. In most organizations that produce tangible products today, machinery does most of the labor to create the product. The employees' role is to tend to the needs of the equipment.

This new structure is referred to in organizational change literature as a socio-technical network. In organizations, as they exist today, there is a formal social network that is composed of mostly functional silos. These silos are connected to

People in this network use each other to test the validity of taking an action before they attempt it.

Every organization has some amount of shadow network that helps keep the equipment running. In Ralph Stacey's book "Complexity and Creativity in Organizations," he states that organizational change is usually first done as an experiment in the shadow network. If the change is strong enough, it replaces the normal way of working,

reliability at a site. Stacey also points out that an organization can be viewed as having many schemas for doing their work and these are the subjects of the changes. These schemas are expressed as routines, habits, procedures, theories in-use, checking and control behaviors, customs, and rituals. The experiment is in the form of choosing a different schema to accomplish their work. Culture

**Formal Socio-technical Network...**

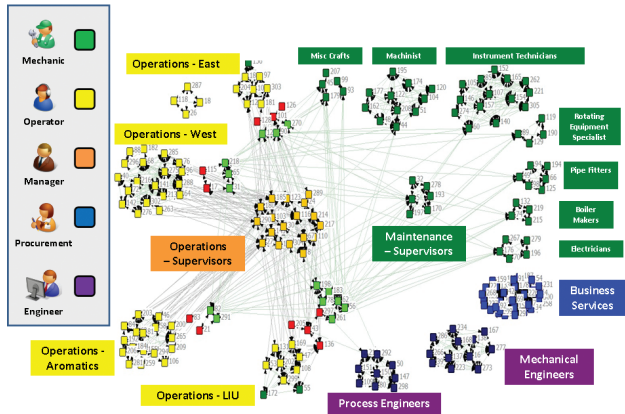

**Shadow Socio-technical Network**

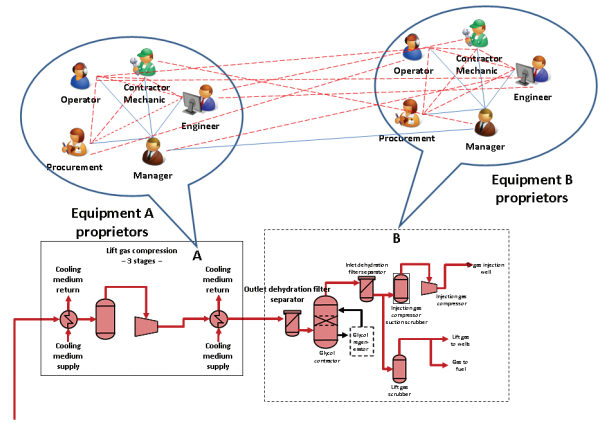

geographical areas of the plant and that determines which equipment the people are responsible for. In addition there is an informal network that Ralph Stacey calls the shadow network. This shadow

Therefore, if an organization wants to improve the reliability of their equipment, the safest way is to find people in the shadow network who are willing to try something new and apply the change. If the change is

change then is created when enough of the schemas are changed so that the majority of people practice the new schemas. This of course requires enough repetitions to

...continued on page 3

## Creating...cont. from page 2

create the new habit.

At one refinery, the organization created a denser socio-technical network over the course of three months. Half of the employees attended workshops where they learned about defect elimination as a new schema to create what they called Proactive Manufacturing. The people attending these workshops were organized into cross-functional action teams at the end of the workshop to go out and apply what they learned about defect elimination to a specific piece of equipment that they were responsible for. Each team attacked a specific defect that they identified, and they took action together to eliminate the root cause of this defect. The actions they took together to eliminate the source of defects then

## How Are...cont. from page 1

mutual fund, at retirement age they would have 2.1 million dollars. And that doesn't include the additional cost of healthcare and insurance for smokers.

Likewise, organizations have spent vast amounts of money on CMMS systems and a great deal of time and money implementing them and then do not use them to their full capacity. Amazingly, we have discovered that at many companies most work orders do not make it into the CMMS system, or if they do they are so vague that they provide little or no meaningful information e.g. "Pump broke". A much more detailed description of what the pump is or is not doing and under what specific conditions would help plan the work and enable maintenance to know what is involved in the repair, and exactly what parts need to be ordered. When CMMS systems were first being developed it made sense that as industry switched from manually tracking work orders to a more automated system there would be some areas that were not as efficient as they should be, but that was more

became the bond between them. Eliminating a chronic problem that they dealt with on a daily basis was meaningful work for the people on the team. This bond then became a new avenue to get work done. In the process of eight workshops the group increased the number of cross functional connections from 3% that existed in the formal network to 17% in the shadow socio-technical network. This began a culture change that was able to reduce the number of work orders by 37.5% in three years and by 70% in eight years. Also it clearly shows the resiliency of the change. The site changed owners and still continued the improvements after a period of flat performance following the change of ownership. This performance mirrors the examples that the DuPont benchmark studies found

than 20 years ago. There is no doubt that companies who are leading their industry sectors are using not only their CMMS systems effectively but also other tools and best practices that have come into existence in the last 20 years. As we lose more and more industrial jobs in the U.S., what is it going to take to get all of the average performing and under performing companies to fully utilize the technological advantages that most of them have?

Making sure that the majority of work orders make it into the site's CMMS can have a tremendous benefit. Just like having planning and scheduling adds organization and order to maintenance work, having work orders in the CMMS allows tracking of the most frequent failures. It builds a library of planned work and allows sharing within a site and between sites of specific equipment repairs. Why wouldn't one do this when the system is already in place and has the capacity to make work more efficient and life easier for all of those involved? It would be similar to having a computer and printer available at your desk but continuing to write all

in Japan in 1991. In the Japanese cases observed in the benchmark studies they claimed to eliminate 90%–98% of the failures. The improvements at the refinery mentioned above have sustained over 10 years, and they eliminated 87% of their pump failures. Their performance, however, is beginning to deteriorate and based on our studies, we recommend that the process be embedded in the Computerized Maintenance Management System to deal with this inevitable deterioration over long periods of time. We also believe that the process can be accelerated if the CMMS is used to drive the change in the beginning.



your work by hand.

Using the CMMS the way it is intended—for all of the work—is a way to get a culture change to occur and to be sustained. It is important to take advantage of the full capability of your CMMS and have it become the keeper of the right habits and instigator of new habits that need to be developed. Begin by writing more specific work orders, then making sure they are put into the CMMS system each time. The next step is adding an improvement to those work orders where warranted. Before you know it, you will have created a new habit. When this is done, you have now taken the reminder for the care of the equipment out of the hands of individuals and put it into the system that is the record keeper for all of the equipment. Let's all pledge with our New Year resolutions to make an effort to change not only some of the bad habits we have as individuals but also the corporate bad habits that have developed over the years that keep us from becoming the kind of company that leads the way.



7702 FM 1960 East, Ste. 226  
 Humble, TX 77346  
 (281) 812-4148  
 (281) 812-4149 Fax  
<http://www.ManufacturingGame.com>  
 email: [info@ManufacturingGame.com](mailto:info@ManufacturingGame.com)



# Winter

**TMG News**

**SCHEDULE**

**Conferences of Interest**

**Reliability Centered  
 Maintenance Managers Forum  
 Fort Meyers, FL  
 March 21-25, 2011**

For more information or to register visit  
[www.MaintenanceConference.com](http://www.MaintenanceConference.com)  
 or call (888) 575-1245

**Mark Your  
 Calendar!**

## What's Happening

**Congratulations to the CH2M HILL Prudhoe Bay, Alaska** project teams for being nominated for the chairman's excellence award. Some of the CH2M HILL teams were featured in our October 2010 TMG News Action Team story. To read the article visit <http://mfg-game.com/newsletters.asp>

---

**Reliable Manufacturing helps Bakkavör achieve Rapid Transformation**

Bakkavör, a leading international food manufacturing group in Europe, approached specialist change management consultants, Reliable Manufacturing, to help them engage their people in proactive problem solving and improvement action. Reliable Manufacturing used their Rapid Transformation Program by incorporating a series of engagement workshops featuring The Manufacturing Game® to help drive change across the organization. The workshops allowed the Bakkavör teams to simulate real-life scenarios from their business and to establish the principles of 'systems thinking'—how the actions of one area impacts another area of the business. As a result, improvement teams were launched to address a range of specific problem opportunities, from changes in the supply of raw materials all the way through to improvements within the invoicing system. The benefits have already shown through in improved output, better yields and reduced costs.

---

*Reliable Manufacturing is a reliability-based change management consultancy licensed by Ledet Enterprises, Inc. to run Manufacturing Game workshops in Europe, Africa and the Middle East. For more information about this article or to inquire about attending a public workshop in these areas visit [www.reliable-manufacturing.com](http://www.reliable-manufacturing.com) or contact Andrew Fraser: [andrew.fraser@reliable-manufacturing.com](mailto:andrew.fraser@reliable-manufacturing.com)*